

Pandangolide 1a, a Metabolite of the Sponge-Associated Fungus *Cladosporium* sp., and the Absolute Stereochemistry of Pandangolide 1 and *iso*-Cladospolide B

Shiri Gesner,[†] Naama Cohen,[‡] Micha Ilan,[‡] Oded Yarden,[§] and Shmuel Carmeli*,[†]

School of Chemistry, Raymond and Beverly Sackler Faculty of Exact Sciences, and Department of Zoology, George S. Wise Faculty of Life Sciences, Tel Aviv University, Ramat Aviv Tel Aviv, 69978, Israel, and Department of Plant Pathology and Microbiology, Faculty of Agricultural, Food and Environmental Quality Sciences, The Hebrew University of Jerusalem, Rehovot, 76100, Israel

Received May 10, 2005

Fractionation of the ethyl acetate extract of a *Cladosporium* sp., isolated from the Red Sea sponge *Niphates rowi*, yielded a new hexaketide, pandangolide 1a (**1**), together with its known diastereomer pandangolide 1 (**2**) and the known *iso*-cladospolide B (**3**). The structures of the compounds were determined by 1D and 2D NMR techniques and mass spectrometric data. The absolute configurations of the stereocenters in these compounds were determined by Riguera's method and circular dichroism.

Marine fungi are attracting increasing attention as a potential source of new pharmaceuticals and pharmaceutical leads.¹ Isolates belonging to cosmopolitan genera, such as *Aspergillus*, *Penicillium*, *Alternaria*, and *Cladosporium*, are a significant source of new secondary metabolites from marine-derived fungi.² Species belonging to these genera are routinely isolated from the surfaces, inner tissues, and internal spaces of marine algae,^{3,4} sponges,⁵ ascidians,⁴ and other marine invertebrates.⁶ To date, more than 75 metabolites from 25 sponge-derived fungal strains have been described.^{5,7,8} Some of these reported metabolites exhibit bioactive properties and are structurally unique, while many others are structurally related to metabolites produced by fungi isolated from terrestrial habitats.⁹ These results led us to investigate marine invertebrate-derived fungi as a source of pharmaceutically active substances. In the course of our study, we isolated a new hexaketide lactone, pandangolide 1a (**1**, 2.4 mg, 1.6% of crude extract), along with its known diastereoisomer pandangolide 1 (**2**, 3.4 mg, 2.3% of crude extract) and the known *iso*-cladospolide B (**3**, 25.7 mg, 17.6% of crude extract), from the ethyl acetate extract of a *Cladosporium* sp. that was isolated from the Red Sea sponge *Niphates rowi*. The absolute configuration of these compounds is proposed on the basis of chemical, spectroscopic, and biosynthetic arguments.

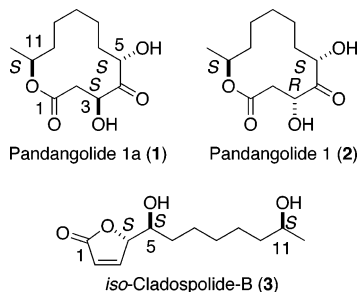

Results and Discussion

The crude EtOAc extract of the culture medium of strain M0467 was separated on a reversed-phase HPLC column

to yield two fractions that appeared to be pure compounds. The first fraction (16.3 mg) was determined to be a 1:1 mixture of compounds **1** and **2** and was further purified by HPLC to afford the new pandangolide 1a (**1**) together with the known pandangolide 1 (**2**). The second fraction was identified as the known *iso*-cladospolide B (**3**). Pandangolide 1 (**2**) is a hexaketide lactone, previously isolated together with *iso*-cladospolide B (**3**), cladospolide B, and related metabolites from a marine fungal species that was cultured from a tissue sample of a marine sponge collected in Indonesia.¹⁰ The absolute configuration of **2** and **3** was not determined.

The mixture of pandangolides 1 (**2**) and 1a (**1**) gave NMR spectra with 24 carbons and 40 protons. The structure elucidation of these hexaketides was first established on the mixture, suggesting either an almost symmetrical bilactone or two isomeric 12-membered lactones. The CIMS spectrum presented a protonated molecular ion at m/z 245 $[MH]^+$, which corresponded to the molecular formula $C_{12}H_{20}O_5$ and thus favored the second option. After separation of the mixture, the CIMS molecular cluster ion of both compounds (**1** and **2**) was identical to that of the mixture, and the HRCIMS of **1** gave an m/z 245.1394 $[MH]^+$, corresponding to the molecular formula $C_{12}H_{20}O_5$. Structure elucidation of **1** was accomplished as follows (see Table 1). H–H COSY correlations established three fragments: C-2 to C-3, C-5 to C-7, and C-8 to C-12; $^1J_{C-H}$ HMQC correlations assigned the protons to the corresponding carbons. Long-range C–H correlations (from HMBC experiment) determined the connection of C-1 to C-2, C-3 and C-5 to C-4, and C-7 to C-8 to yield the dodecanoic chain. Finally, correlation of H-11 with C-1 established the lactone moiety of **1**. Comparison of the NMR data of the two pure isomers (see Table 1) suggested that they differed in the configuration of C-3 since the carbon chemical shift differences peaked for C-3 (3.0 ppm) and declined to both sides of C-11 (0.1 ppm) and C-6 (0.4 ppm). Comparison of the 1H and ^{13}C NMR data and optical rotations of both compounds (**1** and **2**) with the NMR data in CD_3OD and optical rotations in MeOH of pandangolide 1 revealed that compound **2** was identical in all respects to pandangolide 1.¹⁰

The absolute stereochemistry of compounds **1** and **2** was determined using Riguera's method for the determination of the absolute stereochemistry of secondary alcohols.¹¹ According to this method, samples of compounds **1** and **2**

* To whom correspondence should be addressed. Tel: +972-3-6408550. E-mail: carmeli@post.tau.ac.il.

[†] School of Chemistry, Tel Aviv University.

[‡] Department of Zoology, Tel Aviv University.

[§] The Hebrew University.

Table 1. NMR Data of Pandangolide 1a (**1**) and Pandangolide 1 (**2**)^a

position	pandangolide 1a (1)			pandangolide 1 (2)	
	δ_C , mult. ^b	δ_H , mult., <i>J</i> (Hz)	HMBC corr. ^b	δ_C , mult.	δ_H , mult., <i>J</i> (Hz)
1	172.5 qC		H-2a, H-2b, H-3, H-11	174.2 qC	
2	40.5 CH ₂	2.99 dd 18.1, 2.7 3.16 dd 18.1, 8.5	H-3	42.3 CH ₂	3.05 dd 18.9, 6.9 3.20 dd 18.9, 2.8
3	68.6 CH	4.51 dd 8.5, 2.7	H-2a, H-2b	65.6 CH	4.55 dd 6.9, 2.8
4	212.3 qC		H-2a, H-2b, H-3, H-5, H ₂ -6	210.7 qC	
5	76.1 CH	4.17 dd 7.6, 3.7	H ₂ -6	76.6 CH	4.18 dd 7.4, 4.1
6	30.8 CH ₂	1.89, 1.91 m	H-5	30.4 CH ₂	1.75, 1.89 m
7	19.8 CH ₂	1.22 m	H ₂ -6, H ₂ -8	19.3 CH ₂	1.28 m
8	26.7 CH ₂	1.21 m	H ₂ -9, H ₂ -10	26.6 CH ₂	1.21 m
9	22.2 CH ₂	1.45 m	H ₂ -8, H ₂ -10	21.4 CH ₂	1.45 m
10	33.2 CH ₂	1.38 m	H ₂ -11	32.4 CH ₂	1.58 m
11	74.4 CH	4.87 ddq 3.8, 7.5, 6.2	H ₂ -10, H ₃ -12	74.5 CH	4.87 ddq 3.9, 7.5, 6.2
12	19.5 CH ₃	1.27 d 6.2	H ₂ -10, H ₂ -11	20.3 CH ₃	1.20 d 6.2

^a Carried out on an Avance-400 Bruker instrument in CDCl₃+CD₃OD. ^b Multiplicity and assignment was obtained from an HMQC experiment. ^c Determined from an HMBC experiment, ⁿ*J*_{CH} = 8 Hz, recycle time 1 s.

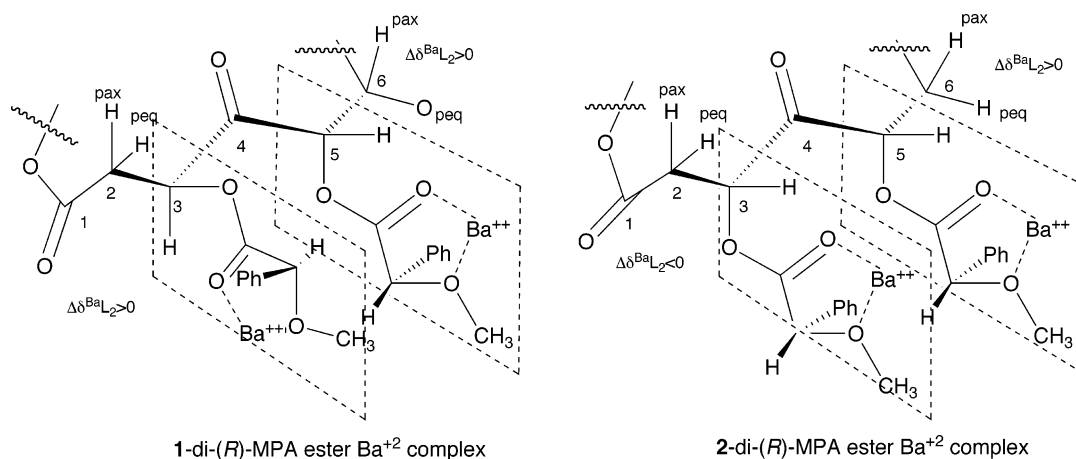
**Figure 1.** *syn*-Periplanar conformers of the Ba²⁺ complexes of di-(*R*)-MPA esters of **1** and **2**.**Table 2.** ¹H NMR Shifts of the MPA Ester of Compounds **1** and **2** before and after the Addition of the Ba(ClO₄)₂ Salt

position	MPA ester of 1 ^a			MPA ester of 2 ^b		
	δ_H , mult., <i>J</i> (Hz)	δ_H , mult., <i>J</i> (Hz) Ba(ClO ₄) ₂	$\Delta\delta^{Ba}$	δ_H , mult., <i>J</i> (Hz)	δ_H , mult., <i>J</i> (Hz) Ba(ClO ₄) ₂	$\Delta\delta^{Ba}$
2peq	2.60 dd (3.0, 18.2)	2.79 dd (3.0, 18.2)	-0.19	3.14 dd (3.4, 19.5)	3.22 dd (3.4, 19.5)	-0.08
2pax	3.41 dd (10.3, 18.2)	3.33 dd (10.2, 18.2)	+0.08	3.30 dd (5.8, 19.5)	3.40 dd (5.8, 19.5)	-0.10
3	5.57 dd (3.0, 10.3)	5.47 dd (3.0, 10.2)	+0.10	5.49 dd (3.4, 5.8)	5.52 dd (3.4, 5.8)	-0.03
5	5.00 dd (4.1, 6.9)	5.02 dd (4.1, 6.9)	-0.02	5.13 dd (1.9, 7.5)	5.13 dd (2.3, 7.7)	0
6peq	1.81 m	1.72 m	+0.09	1.96 m	1.87 m	+0.09
6pax	1.73 m	1.56 m	+0.17	1.78 m	1.74 m	+0.04
7peq	1.36 m	1.26 m	+0.10	1.29 m	1.20 m	+0.09
7pax	1.10 m	1.03 m	+0.07	1.08 m	0.85 m	+0.23
11	4.83 ddq (3.0, 12.9, 6.5)	4.73 ddq (3.2, 12.8, 6.5)	+0.10	4.70 ddq (2.4, 12.8, 6.3)	4.60 ddq (2.4, 12.8, 6.3)	+0.10
12	1.19 d (6.5)	1.09 d (6.5)	+0.10	1.15 d (6.3)	1.09 d (6.3)	+0.06

^a 400 MHz, δ in ppm. ^b 500 MHz δ in ppm.

were first reacted with (*R*)-MPA reagent. The ¹H NMR and COSY spectra of the resulting MPA esters were recorded in acetonitrile-*d*₃. Next, solid anhydrous Ba(ClO₄)₂ was added to the NMR tube until saturation was attained and new ¹H NMR and COSY spectra were recorded. The formation of the barium(II) complex with the MPA ester moves the conformational equilibrium between the *syn*- (*sp*) and *anti*-periplanar (*ap*) forms of the MPA ester toward the more stable *syn*-periplanar (*sp*) conformation (see Figure 1). These conformational changes led to a decrease in the shielding of the MPA phenyl group on certain protons of compounds **1** and **2**. As a result, the NMR signals of these protons are shifted to a lower field. In contrast, other protons are more shielded by the MPA phenyl group, and as a consequence, their signals are shifted to a higher field. The chemical shifts before and after the addition of

the barium salt to the MPA esters of **1** and **2** are summarized in Table 2.

In compound **1**, the NMR signal of H-2peq is shifted to a lower field ($\Delta\delta^{BaL_2} < 0$), while H-2pax is shifted to a higher field ($\Delta\delta^{BaL_2} > 0$). In compound **2**, the NMR signals of H-2peq and H-2pax are shifted to a lower field ($\Delta\delta^{BaL_2} < 0$). According to Riguera's method,¹¹ L₁ and L₂ groups must have opposite signs. Considering the ¹³C chemical shift differences (see above), and the *J*_{2pax,3} and *J*_{2peq,3} of the di-MPA esters of both **1** and **2** (see Table 2), which suggest that the C-3 stereochemistry is reversed in both compounds, we decided that the H-2pax shift to a higher field represents compound **1** together with a shift of H-5 to a lower field ($\Delta\delta^{BaL_1} < 0$). The experimental results ($\Delta\delta^{BaL_1} < 0$ and $\Delta\delta^{BaL_2} > 0$) led us to the conclusion that the absolute configuration of C-3 is *S*. The determination

Table 3. ^1H NMR Shifts of the MPA Ester of Compound **3** before and after the Addition of the $\text{Ba}(\text{ClO}_4)_2$ Salt^a

position	δ_{H} MPA ester	δ_{H} MPA ester + $\text{Ba}(\text{ClO}_4)_2$	$\Delta\delta^{\text{Ba}}$
2	7.39	7.69	-0.30
3	5.99	6.17	-0.18
4	5.09	5.17	-0.08
5	5.04	5.01	+0.03
6	1.73	1.60	+0.13
10	1.50	1.51	-0.01
11	4.80	4.70	+0.10
12	1.15	1.13	+0.02

^a 400 MHz, δ in ppm.

of the absolute configuration of C-5 is based mainly on the $\Delta\delta$ values of protons 6peq, 6pax, 7peq, and 7pax that belong to the L_2 group of C-5. Upon addition of the barium salt, these protons shifted to a higher field ($\Delta\delta^{\text{Ba}}L_2 > 0$). On the basis of Riguera's method ($\Delta\delta^{\text{Ba}}L_2 > 0$), we determined the stereogenic center at position 5 to be *S*.

The absolute configuration of compound **2** was determined in a similar way. The absolute configuration of the stereogenic center at position 3 was determined according to the NMR shifts of protons 2peq and 2pax. As a result of the addition of the barium salt, the NMR signals of these protons were shifted to a lower field ($\Delta\delta^{\text{Ba}}L_2 < 0$) and led us to the conclusion that the absolute configuration of C-3 is *R*. The $\Delta\delta^{\text{Ba}}$ value of H-3 is negative, while those of protons 6peq, 6pax, 7peq, and 7pax are positive. According to these experimental results ($\Delta\delta^{\text{Ba}}L_1 < 0$, $\Delta\delta^{\text{Ba}}L_2 > 0$), the absolute configuration of C-5 was determined to be *S*.

Compound **3** was isolated by Ireland's group, which did not determine its absolute configuration. In a recent paper, Franck et al.¹² suggested the stereochemistry of **3**. In their paper, they describe a synthesis of two pairs of mixtures of the 4,5-*erythro*- and 4,5-*threo*-11*R* isomers of **3**. On the basis of the comparison of the optical rotation values and ^1H and ^{13}C NMR chemical shifts of the enantiomeric mixtures with the values of the natural products, they could not unambiguously determine the absolute configuration of the stereogenic centers of **3** but rather assume that **3** has the 4*S*,5*S* configuration. On the basis of an analogy with cladospolide B (a previously known metabolite that was isolated with **3** by Ireland's group), they suggest an 11*R* absolute configuration for **3**, but comment that only analysis of the Mosher esters of the natural products will allow unambiguous determination of the absolute configuration at C-11.

We decided to check these findings by spectroscopic methods. The absolute configurations of carbons 5 and 11 of compound **3** were determined by Riguera's method for secondary alcohols, as mentioned above. The aromatic ring of the C-5-MPA moiety shields the protons at positions 2, 3, and 4. As a result of the addition of the barium salt, the more stable conformation was favored and the NMR signals of these protons were shifted to a lower field (negative $\Delta\delta^{\text{Ba}}$ values) (see Table 3). Protons 2, 3, and 4 belong to the L_1 group with respect to C-5, meaning that $\Delta\delta^{\text{Ba}}L_1 < 0$. In addition, the NMR signals of the protons at position 6, which belong to the L_2 group, were shifted to a higher field (positive $\Delta\delta^{\text{Ba}}$ values). On the basis of the experimental results ($\Delta\delta^{\text{Ba}}L_1 < 0$ and $\Delta\delta^{\text{Ba}}L_2 > 0$) obtained by Riguera's method, the *S* absolute configuration was assigned to C-5. The stereochemistry of C-11 was determined in a similar way. As a result of the addition of the barium salt, the ^1H NMR signals of the protons of the methyl group at position 12 were shifted to a higher field ($\Delta\delta^{\text{Ba}}L_2 > 0$). In contrast, the ^1H NMR signals of the protons at position 10 were shifted to a lower field ($\Delta\delta^{\text{Ba}}L_1 < 0$). According to these

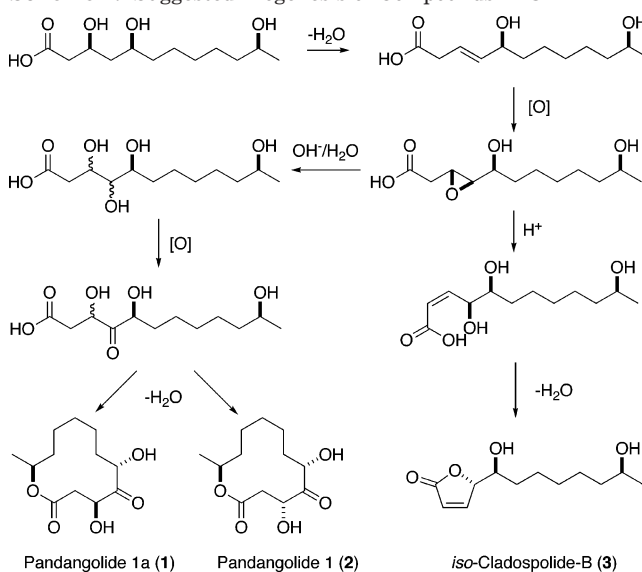
Scheme 1. Suggested Biogenesis of Compounds **1–3**

results, the absolute stereochemistry of C-11 was also determined to be *S*.

The stereogenic center at position 4 was determined using circular dichroism measurements. The chromophore of the α,β -unsaturated lactone in the butenolide ring is achiral and becomes optically active in the presence of a perturber at the stereogenic center at position 4. The observed Cotton effects due to the $n-\pi^*$ (235–250 nm) and $\pi-\pi^*$ (200–220 nm) transitions of the α,β -unsaturated lactone chromophore are correlated directly from the absolute configuration of the stereogenic center.¹³ Right-handed helicity of the $\text{R}-\text{C}(4)-\text{C}=\text{C}$ bond system gives rise to a negative $n-\pi^*$ and a positive $\pi-\pi^*$ Cotton effect. The opposite sign pattern is observed for the left-handed helicity of this bond system. The CD spectra of compound **3** showed a negative Cotton effect at 216 nm.¹³ According to this result, we determined that the stereogenic center at position 4 is *S*. On the basis of these results we suggest the 4*S*,5*S*,11*S* stereochemistry for **3**. The absolute stereochemistry assigned to positions 4 and 5 is similar to that suggested by Franck et al.,¹² yet our analysis contradicts their assumption that the stereochemistry at position 11 is similar to that of cladospolide B that was isolated together with *iso*-cladospolide B (**3**).¹⁰

On the basis of biosynthetic considerations, shown in Scheme 1, a common trihydroxydodecanoic acid-polyketide precursor is suggested for compounds **1–3**. We suggest that the stereochemistry of C-11 in pandangolides 1a (**1**) and 1 (**2**) is *S*, similar to that of *iso*-cladospolide B (**3**), considering the function of type I modular PKS in generating a polyketide chain.¹⁴

Experimental Section

General Experimental Procedures. Optical rotations were determined on a JASCO P-1010 polarimeter. CD spectra were recorded on a JASCO Aviv model 215 circular dichroism spectrometer. UV spectra were obtained on a UVIKON 931 spectrophotometer. IR spectra were obtained on a Bruker Vector 22 spectrometer. ^1H and ^{13}C NMR spectra were obtained on Bruker ARX500 and Avance 400 spectrometers, using tetramethylsilane as the internal standard. Electron impact mass spectra were obtained on a VG AutoSpecQ M 250 spectrometer.

Fungal Strain Isolation, Identification, and Fermentation. The fungal strain was isolated from a fresh sample of *Niphates rowi*, a shallow water Red Sea sponge,¹⁵ collected by

scuba from the Gulf of Aqaba, in May 2002. Following a rinse with sterile seawater, small pieces of the inner tissue of the sponge were inoculated on KMV agar Petri dishes. The sterilized KMV medium (prepared with seawater) contained glucose (1 g/L), gelatin hydrolizate (1 g/L), yeast extract (0.1 g/L), bacto peptone (0.1 g/L), granulated agar (15 g/L), and chloramphenicol (0.25 g/L). Emerging fungal colonies were transferred to potato dextrose agar (PDA, Difco) in a Petri dish and incubated at 25 °C for 7 days to allow colony development and conidiation. The strain, designated M0467, was identified as belonging to the genus *Cladosporium* by morphological and molecular (18S rDNA; accession number DQ100370) phylogenetic methods.^{16,17} Production fermentation was performed in 250 mL (75CM2) sterile tissue flasks containing 24 g of potato dextrose broth (PDB, Difco) per liter of seawater. Fifteen flasks were incubated at 25 °C for 10–14 days.

Extraction and Isolation. Extraction of the mycelium-free culture medium (3 L) with EtOAc (3 × 0.7 L) afforded a crude extract (146 mg). The EtOAc-soluble portion (146 mg) was separated on an HPLC column (YMC Pack ODS-AQ, 20.0 mm × 250 mm, 10 μm; flow rate 5 mL/min; UV detection at 210 nm; eluent MeCN/H₂O, 55:45) to give, in fraction 1 (*t*_R 14.8 min, 16.3 mg, 11.1% yield of crude extract), a diastereomeric mixture of **1** and **2** and, in fraction 2, *iso*-cladospolide B (3, *t*_R 12.6 min, 25.7 mg, 17.6% yield of crude extract). Fraction 1 was further separated on a semipreparative HPLC column (YMC Pack column A-324 120A ODS 10 mm × 300 mm, flow rate 2.2 mL/min; UV detection at 210 nm; eluent MeCN/MeOH/H₂O, 25:5:70) to obtain pandangolide 1a (**1**, *t*_R 13.4 min, 2.4 mg, 1.6% yield of crude extract) and pandangolide 1 (**2**, *t*_R 13.5 min, 3.4 mg, 2.3% yield of crude extract).

Pandangolide 1a (1): white solid; [α]_D²⁵ −25° (c 1.6, MeOH); UV (MeOH) λ_{max} (log ε) 205 (2.90) nm; IR (CHCl₃) ν_{max} 1220, 1715, 1732, 2934, 3550 cm⁻¹; ¹H and ¹³C NMR (see Table 1); CIMS *m/z* 245 [MH]⁺ (100); HRCIMS *m/z* 245.1394 (calcd for C₁₂H₂₁O₅, *m/z* 245.1388).

Pandangolide 1 (2): white solid; [α]_D²⁵ −30° (c 2.3, MeOH); UV (MeOH) λ_{max} (log ε) 205 (2.90) nm; IR (CHCl₃) ν_{max} 1220, 1716, 1732, 2934, 3552 cm⁻¹; ¹H and ¹³C NMR (see Table 1); CIMS *m/z* 245 [MH]⁺ (100).

***iso*-Cladospolide B (3):** yellow solid; [α]_D²⁵ −61° (c 16.6, MeOH); UV (MeOH) λ_{max} (log ε) 210 (3.36) nm; IR (CHCl₃) ν_{max} 785, 1757, 3021, 3615, 3670 cm⁻¹; ¹H and ¹³C NMR (see Table 3); CIMS *m/z* 229 [MH]⁺ (38), 211 (100), 127 (41), 109 (40), 85 (42); CD (c 16.9 mM, MeOH) Δε (nm) −41.0 (241), +0.9 (275).

Preparation of the Di-(*R*)-MPA Esters of Compounds 1–3. A 2.0 mg (8 μM) sample of each of the isolated compounds, **1–3**, was treated with (*R*)-methoxy phenyl acetic acid (20 μM), DCC (20 μM), and DMAP (0.8 μM) in methylene

chloride (10 mL) for 24 h at room temperature.¹⁸ The reaction mixture was worked up, and the resulting di-MPA esters of **1–3** were dissolved in CD₃CN for NMR measurements.

Acknowledgment. We thank the director and staff of the Interuniversity Institute (IUI) for Marine Sciences in Eilat for assistance during the study and S. Hauptman for mass spectra measurements. The research was conducted within the framework of the National High Throughput Screening Center for novel bioactive compounds located at Tel Aviv University and supported by the Israel Ministry of Science grant 432-201.

Supporting Information Available: Comparison of the NMR data of compounds **2** and **3** with data from the literature. This material is available free of charge via the Internet at <http://pubs.acs.org>.

References and Notes

- Biabani, M. A. F.; Laatsch, H. *J. Prakt. Chem.* **1998**, *340*, 589–607.
- Jensen, P. R.; Fenical, W. In *Fungi in Marine Environments: Secondary Metabolites from Marine Fungi*; Hyde, K. D., Ed.; Fungal Diversity Press: Hong Kong, 2002; Fungal Diversity Research Series 9, pp 293–315.
- Osterhage, C.; Konig, G. M.; Holler, U.; Wright, A. D. *J. Nat. Prod.* **2002**, *65*, 306–313.
- Garro, E.; Starks, C. M.; Jensen, P. R.; Fenical, W.; Lobkovsky, E.; Clardy, J. *J. Nat. Prod.* **2003**, *66*, 423–426.
- Bugni, T. S.; Bernan, V. S.; Geenstein, M.; Janso, J. E.; Maiese, W. M.; Mayne, C. L.; Ireland, C. M. *J. Org. Chem.* **2003**, *68*, 2014–2017.
- Tsuda, M.; Mugishima, T.; Komatsu, K.; Sone, T.; Tanaka, M.; Mikami, Y.; Kobayashi, J. *J. Nat. Prod.* **2003**, *66*, 412–415.
- Holler, U.; Wright, A. D.; Mathee, G. F.; Konig, G. M.; Drager, S.; Aust, H.-J.; Schulz, B. *Mycol. Res.* **2000**, *104*, 1354–1365.
- Porksich, P.; Ebel, R.; Edrada, R. A.; Schupp, P.; Lin, W. H.; Sudarsono, Wary, V.; Steube, K. *Pure Appl. Chem.* **2003**, *75*, 343–352.
- Faulkner, D. *Nat. Prod. Rep.* **2002**, *19*, 1–48. Blunt, J. W.; Copp, B. R.; Munro, M. H. G.; Northcote, P. T.; Prinsep, M. R. *Nat. Prod. Rep.* **2005**, *22*, 15–61, and references therein.
- Smith, C. J.; Abbanat, D.; Bernan, V. S.; Maiese, W. M.; Greenstein, M.; Jompa, J.; Tahir, A.; Ireland, C. M. *J. Nat. Prod.* **2000**, *63*, 142–145.
- Garcia, R.; Seco, J. M.; Vazques, S. A.; Quinoa, E.; Riguera, R. *J. Org. Chem.* **2002**, *67*, 4579–4589.
- Franck, X.; Vaz Araujo, E.; Hocquemiller, R.; Figadere, B. *Tetrahedron Lett.* **2001**, *42*, 2801–2803.
- Gawronski, J. K.; Van Oeveren, A.; Van Der Deen, H.; Leung, C. W.; Feringa, B. L. *J. Org. Chem.*, **1996**, *61*, 1513–1515.
- Staunton, J.; Weissman K. *J. Nat. Prod. Rep.* **2001**, *18*, 380–416.
- Ilan, M.; Gugel, J.; Van Soest, R. W. M. *Sarsia* **2004**, *89*, 388–410.
- Gardes, M.; Bruns, T. D. *Mol. Ecol.* **1993**, *2*, 113–118.
- Wirsal, S. G. R.; Runge-Froböse, C.; Ahrén, D. G.; Kemen, E.; Oliver, R. P.; Mendegen, K. W. *Fung. Genet. Biol.* **2002**, *35*, 99–113.
- Trost, B. M.; Belletire, J. L.; Godleski, S.; McDougal, P. G.; Balkovec, J. M.; Baldwin, J. J.; Christy, M. E.; Ponticello, G. S.; Vagra, S. L.; Springer, J. P. *J. Org. Chem.* **1986**, *51*, 2370–2374.

NP0501583